

# 757-2V PR PANORAMIQUE

## 11kW

**GODIN** CHAUFFAGE  
CHEMINÉES  
CUISINIÈRES

### Foyer étanche porte avec relevable

FP-CG-0511-01

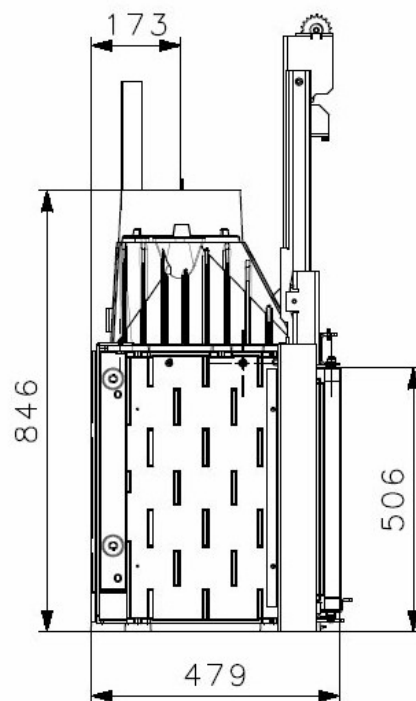
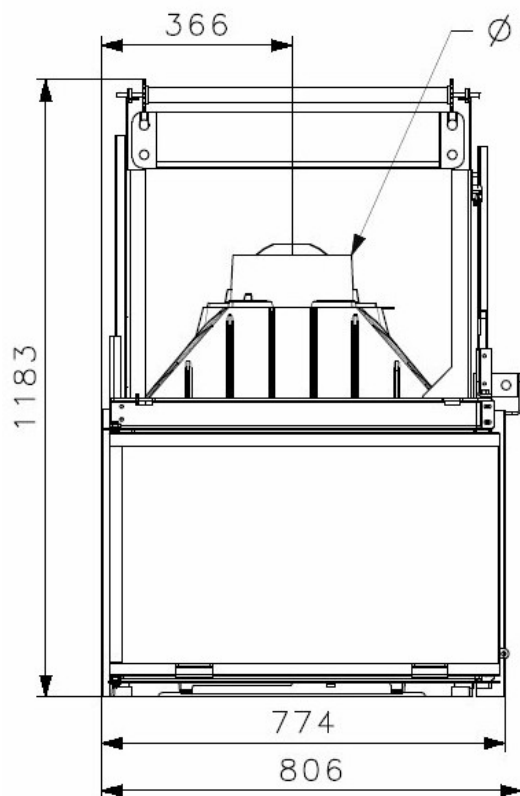

### Caractéristiques:

Puissance: 11kW  
Bûche 50cm  
Rendement : 77,4%  
Co : 0,088%  
Particules : 33mg/Nm<sup>3</sup>  
Cov : 75,84mg/Nm<sup>3</sup>  
Nox : 123,11mg/Nm<sup>3</sup>

Niveau : A  
EEI : 88  
Indice I' : 0,5  
NF EN 13229  
Arrivée d'air : NC  
Sortie : dessus Ø 230



### Principaux avantages :

Combustion haute performance  
Fabrication Française  
Flamme verte 7\*  
Ecodesign  
Double combustion  
Porte relevable

flamme  
VERTE

Le label  
du chauffage  
au bois

Appareil de classe  
**7★**

DOUBLE  
COMBUSTION